

COMPACT EXCAVATOR

# TB320

**takeuchi**<sup>TM</sup>  
From World First to World Leader

PROUDLY DISTRIBUTED BY



**MATERIAL HANDLING**

**1800 425 438**

[toyotatakeuchi.com.au](http://toyotatakeuchi.com.au)



Operating Weight: 2,060 kg

# TOUGH, POWERFUL, RELIABLE

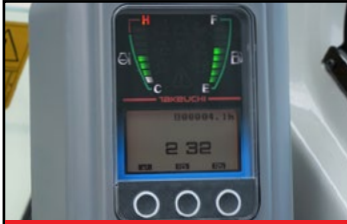

3.5" Color Display



Multiple Service Ports (Up to 4)



Hydraulic Joystick Controls



Large Floor with Foot Rest

Designed to work in confined and demanding applications, the Takeuchi TB320 features many advancements in performance and technology that make it an extremely versatile and productive machine. It is easy to transport and well suited for working in a wide range of applications from urban construction sites to areas with limited access such as around businesses, apartments, and homes. A key feature of the TB320 is the hydraulically controlled, variable width undercarriage that can retract to 980 mm and expand to 1370 mm wide. With the undercarriage fully retracted, the machine is able to maneuver easily through narrow passages to get to the work site. Once on-site, the undercarriage can be expanded to provide optimum balance and stabilization.

Available in canopy/cab configurations, the operator's station provides all day comfort with an adjustable suspension seat, large floor area with integrated foot rests, ergonomically designed pilot controls, and adjustable arm rests. The 3.5" multifunction display shows key machine information at a glance.

The TB320 is a conventional tail swing excavator making it a very stable platform that provides excellent lift capacity. It is also available with up to four auxiliary circuits making it easy to add hydraulically driven attachments. The primary auxiliary circuit features best in class auxiliary flow of up to 40 L/min and it is controlled using a proportional slider switch located on the left joystick allowing the operator to meter flow to the attachment.



Spacious Automotive Styled Interior with Intuitive Operator Controls

# Product Features & Specifications

## ENGINE

- EU Stage V Emission Compliant
- Engine Preheat Starting Aid
- Double Element, Air Cleaner
- Automatic Fuel Bleed System
- High Capacity Fuel Filters
- High Capacity Radiator and Hydraulic Oil Cooler
- Engine Safety Start System (Left Console)

## ELECTRICAL

- 3.5" Multifunction Color Display
- Weather Resistant Rocker Switches
- 12 volt System with 40 amp Alternator
- LED Light Package ; Boom and Front Cab/Canopy
- Hour Meter / Trip Meter
- Beacon Socket (Cab Only)
- Travel Alarm (optional)
- TFM (Takeuchi Fleet Management, GPS) (optional)
- TSS (Takeuchi Security System, Immobilizer) (optional)\*

## TAKEUCHI FLEET MANAGEMENT

- Minimize Downtime
- Remote Diagnostics
- Utilization Tracking
- Proactive Maintenance
- Control Costs

## UNDERCARRIAGE AND FRAME

- Triple Flange Track Rollers
- Hydraulically Retractable Track Frame (980 mm to 1,370 mm)
- Adjustable Width Backfill Blade
- 2-Speed Travel with Automatic Shift
- Large Wrap Around Counterweight
- Boom Swing Pedal with Foldable Guard
- 230 mm Rubber Crawlers
- 230 mm Steel Crawlers (optional)
- Check Valve, Dozer Blade (optional)

## OPERATOR'S STATION

- ROPS/TOPS/OPG (TOP Guard, Level I)
- Suspension Adjustable Seat
- 2" Retractable Seat Belt
- 12V Power Outlet
- Cab with Heat, Defrost, Windshield Wiper and Washer, Skylight, AM/FM/Bluetooth Radio
- OPG Level I Front Guard (Cab Optional)
- DAB/DAB+ Radio with Bluetooth Hands-free Function (Cab Optional)

## HYDRAULIC

- Variable Displacement Pump
- Straight Travel Circuit
- Hydraulic Joystick Controls
- Auxiliary Hydraulic Circuit Plumbed to Arm
- Proportional Control for Service Port 1
- Proportional Control for Service Port 2 (optional)
- Service Port 3 for Quick Hitch (optional)
- Proportional Control for Service Port 4 (optional)
- Hydraulic Tank with Fluid Sight Gauge
- Hydraulic Selector Valve (1-way / 2-way)
- Air Breather, Hydraulic Tank
- Pilot Accumulator (optional)

## WORKING EQUIPMENT

- Boom Swing
- Cushioned Boom and Swing Cylinders
- Top Mount Boom Cylinder
- Boom Swing Stopper
- 1,130 mm Arm
- Arm Holding Valve (optional)
- Boom Holding Valve with Lift Alarm (optional)
- Lifting Point of Bucket Linkage (optional)



\*Functions may not be available in all countries, so please consult your Takeuchi dealer for details.

## OPERATING PERFORMANCE

Operating Weight - Cab	2,060 kg
Operating Weight - Canopy	1,930 kg
Bucket Capacity (Heaped)	0.038 m <sup>3</sup>
Slew Speed	9.5 min <sup>-1</sup>
Travel Speed	
1st	2.4 km/h
2nd	4.5 km/h
Gradeability	15°
Ground Pressure - Cab	33.0 kPa
Ground Pressure - Canopy	30.9 kPa
Maximum Bucket Breakout Force	17.0 kN
Maximum Arm Digging Force	9.1 kN
Traction Force	21.1 kN
Boom Swing Angle (Left/Right)	78° / 49°

## ENGINE

Model	Yanmar / 3TNV70
Rated Output (ISO 14396)	12.0 kW / 2,500 min <sup>-1</sup>
Maximum Torque	52.7 Nm / 1,800 min <sup>-1</sup>
Displacement	854 ml
Alternator	12V - 0.48 kW
Battery (IEC 60095-1)	12V - 45 A · h

## FLUID CAPACITY

Engine Lubrication	2.8 L
Cooling System	4.1 L
Fuel Tank Capacity	22 L
Hydraulic Reservoir Capacity	16 L
Hydraulic System Capacity	35 L

## HYDRAULIC SYSTEM

P1, P2	Variable Displacement Pump
Flow Rate	20.0 L/min
Relief Pressure	21.0 MPa
P3	Gear Pump
Flow Rate	11.3 L/min
Relief Pressure	18.0 MPa
Service Port 1	
Flow Rate	40.0 L/min
Hydraulic Pressure	21.0 MPa
Service Port 2	
Flow Rate	11.3 L/min
Hydraulic Pressure	18.0 MPa
Service Port 3	
Hydraulic Pressure	18.0 MPa
Service Port 4	
Flow Rate	11.3 L/min
Hydraulic Pressure	18.0 MPa

## SAFETY and HEALTH

Vibration Levels	
Hand / Arm	≤ 2.5 m/s <sup>2</sup>
Body	≤ 0.5 m/s <sup>2</sup>
Noise Level	
Sound Power Level	L <sub>WA</sub> 93 dB



LED Work Lights



All Steel Construction



Top Mount Boom Cylinder



Retractable Undercarriage

# TB320 Compact Excavator

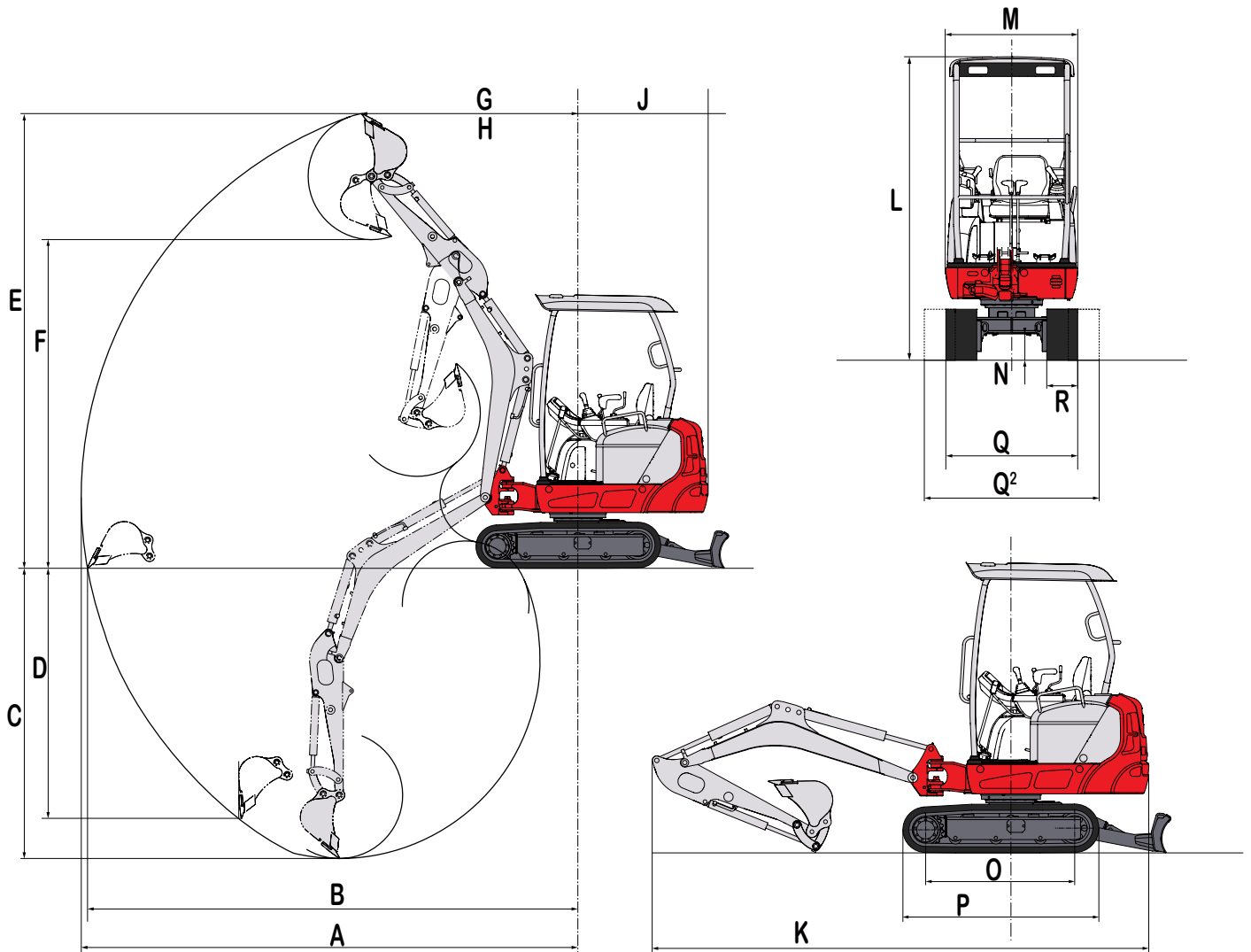

## MACHINE DIMENSIONS

1,130 mm Arm

A	Maximum Reach	4,090 mm
B	Maximum Reach at Ground Level	4,035 mm
C	Maximum Digging Depth	2,370 mm
D	Maximum Vertical Digging Depth	2,040 mm
E	Maximum Height of Cutting Edge	3,760 mm
F	Maximum Dumping Height	2,725 mm
G	Front Swing Radius	1,485 mm
H	Front Swing Radius with Boom Offset	1,155 mm
J	Slew Radius	1,110 mm
K	Overall Length	3,910 mm
L	Overall Height	2,300 mm
M	Upper Structure Overall Width (Cab/Canopy)	1,050 mm / 985 mm
N	Ground Clearance	205 mm
O	Crawler Base	1,205 mm
P	Crawler Overall Length	1,570 mm
Q	Crawler Overall Width - Crawler Retracted	980mm
Q <sup>2</sup>	Crawler Overall Width - Crawler Extended	1,370 mm
R	Crawler Shoe Width	230 mm



PROUDLY DISTRIBUTED BY



**MATERIAL HANDLING**

**1800 425 438**

[toyotatakeuchi.com.au](http://toyotatakeuchi.com.au)

© 2023 Takeuchi MFG. Co., Ltd. All Rights Reserved. In accordance with our established policy of continued improvement, specifications and features are subject to change without notice. Pictures may show options other than standard equipment.

FORM: TB320 Compact Excavator Spec Sheet - Oct. 2023