

COMPACT EXCAVATOR

TB217R

takeuchiTM

From World First to World Leader

PROUDLY DISTRIBUTED BY



MATERIAL HANDLING

1800 425 438

toyotatakeuchi.com.au



Operating Weight: 1,680 kg

Product Features & Specifications

ENGINE

- EU Stage V Emission Compliant
- Engine Preheat
- Extended Life Coolant
- Double Element, Air Cleaner (Optional)
- Automatic Fuel Bleed System
- High Capacity Fuel Filters
- Engine Safety Start System on the Left Console

ELECTRICAL

- Multi-Informational Display
- 12 volt System with 40 amp Alternator
- 2 Canopy Lights
- 1 Working Light on Boom
- TFM (Takeuchi Fleet Management, GPS)*
- TSS (Takeuchi Security System; Immobilizer) (Optional)*
- Hour Meter
- Travel Alarm (Optional)

UNDERCARRIAGE AND FRAME

- Triple Flanged Track Rollers
- Hydraulically Retractable Track Frame (980 mm to 1,300 mm)
- Adjustable Width Backfill Blade
- 2-Speed Travel with Automatic Shift
- Heavy Counterweight
- 230 mm Rubber Crawlers

OPERATOR'S STATION

- ROPS / TOPS / OPG (TOP Guard, Level I)
- 12V Power Outlet
- Highback Suspension Adjustable Seat
- 2" Retractable Seat Belt

HYDRAULIC

- Variable Displacement Pump
- Straight Travel Circuit
- Hydraulic Joystick Controls
- Foot Pedal Control for Service Port 1
- Auxiliary Hydraulic Circuit Plumbed to Arm
- Hydraulic Tank with Fluid Level Sight Gauge
- Proportional Control for Service Port 2 (Optional)
- Service Port 3 for Quick Hitch (Optional)
- Hydraulic Selector Valve (1-way/2-way) (Optional)
- Pilot Accumulator (Optional)

WORKING EQUIPMENT

- Independent Mono Boom Swing
- Cushioned Boom and Swing Cylinders
- Top Mount Boom Cylinders
- 930 mm Arm
- 1,130 mm Arm
- Arm and Boom Holding Valve with Lift Alarm (Optional)
- Pattern Change Valve (ISO or G) (Optional)



Under-seat Cover Provides Control Valve Access



Wide Open Engine Cover

*Functions may not be available in all countries, so please consult your Takeuchi dealer for details.

TOUGH, POWERFUL, RELIABLE



2-Speed Travel



Multi-Informational Display



Hydraulic Joystick Controls



Retractable Undercarriage

The TB217R has many features to make any job easier. Standard equipment includes an multi-informational display, automatic travel shift, pilot operated joystick controls, a high capacity cooling system, and convenient filter and service access.

The retractable undercarriage on the TB217R allows the machine to travel through standard doorways and job sites with limited access with ease.

Auxiliary hydraulics and boom pivot are controlled using the foot pedals located on the left and right side of the floor. The standard high back suspension seat provides optimal comfort for the operator.

The TB217R is powerful, tough and versatile. This machine provides exceptional value and demonstrates outstanding performance.



Easy Maintenance and Service Access

OPERATING PERFORMANCE

Operating Weight	1,680 kg
Bucket Capacity (Heaped)	0.038 m ³
Slew Speed	9.2 min ⁻¹
Travel Speed	
1st	2.2 km/h
2nd	4.2 km/h
Gradeability	15°
Ground Pressure	27.0 kPa
Maximum Bucket Breakout Force	14.0 kN
Maximum Arm Digging Force (930 mm Arm)	9.5 kN
Maximum Arm Digging Force (1,130 mm Arm)	8.2 kN
Traction Force	19.4 kN
Boom Swing Angle (Left/Right)	70° / 50°

ENGINE

Model	Yanmar / 3TNV70
Rated Output (ISO 14396)	11.5 kW/2,400 min ⁻¹
Maximum Torque	52.6 Nm/1,800 min ⁻¹
Displacement	854 ml
Alternator	12 V - 0.48 kW
Battery (IEC 60095-1)	12 V - 48 A h

FLUID CAPACITY

Engine Lubrication	2.8 L
Cooling System	3.9 L
Fuel Tank Capacity	22.0 L
Hydraulic Reservoir Capacity	16.1 L
Hydraulic System Capacity	24.0 L

HYDRAULIC SYSTEM

P1, P2	Variable Displacement Pump
Flow Rate	16.8 L/min
Relief Pressure	21.0 MPa
P3	Gear Pump
Flow Rate	10.8 L/min
Relief Pressure	20.0 MPa
Service Port 1	
Flow Rate	33.6 L/min
Hydraulic Pressure	21.0 MPa
Service Port 2	
Flow Rate	10.8 L/min
Hydraulic Pressure	20.0 MPa
Service Port 3	
Hydraulic Pressure	20.0 MPa

SAFETY and HEALTH

Vibration Levels	
Hand / Arm	≤ 2.5 m/s ²
Body	≤ 0.5 m/s ²
Noise Level	
Sound Power Level	LWA 93 dB



Top Mount Boom Cylinder



Operator's Station



High Capacity Fuel Tank



Short Tail Swing

TB217R Compact Excavator

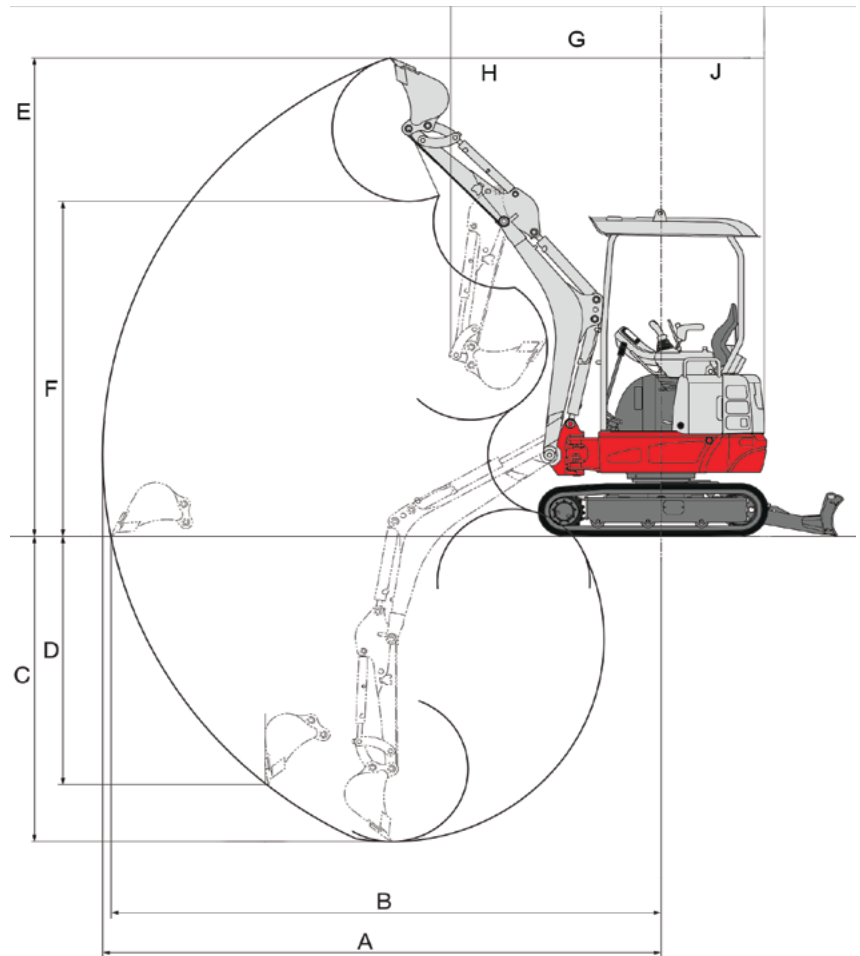
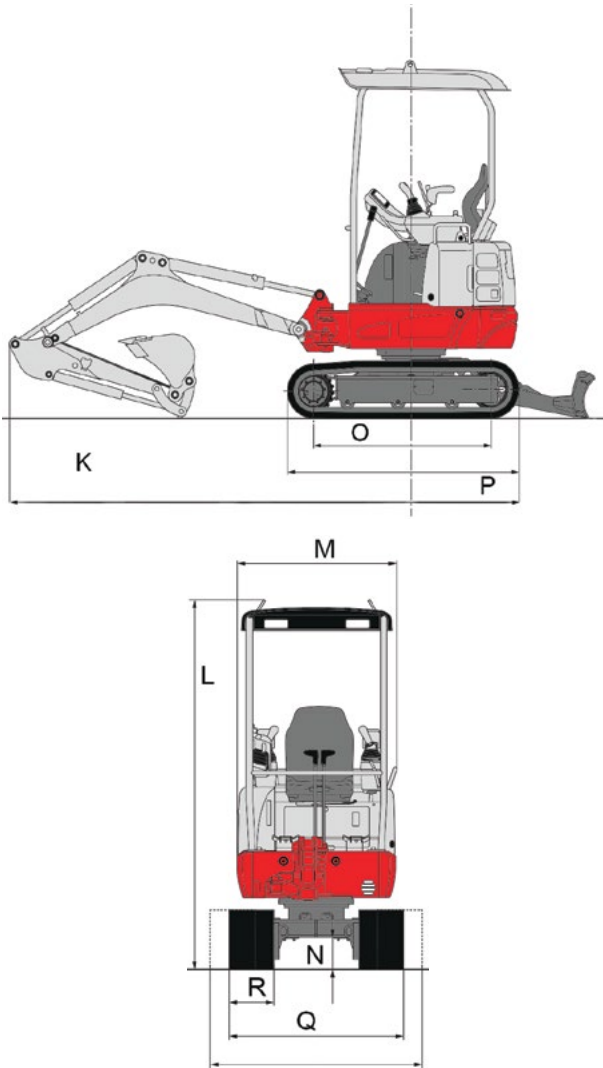

MACHINE DIMENSIONS		930 mm Arm	1,130 mm Arm
A	Maximum Reach	3,815 mm	4,000 mm
B	Maximum Reach at Ground Level	3,760 mm	3,945 mm
C	Maximum Digging Depth	2,190 mm	2,390 mm
D	Maximum Vertical Digging Depth	1,780 mm	1,970 mm
E	Maximum Height of Cutting Edge	3,430 mm	3,570 mm
F	Maximum Dumping Height	2,400 mm	2,545 mm
G	Front Swing Radius	1,450 mm	1,470 mm
H	Front Swing Radius with Boom Offset	1,185 mm	1,210 mm
J	Slew Radius	730 mm	730 mm
K	Overall Length	3,460 mm	3,460 mm
L	Overall Height	2,345 mm	2,345 mm
M	Upper Structure Overall Width	980 mm	980 mm
N	Ground Clearance	205 mm	205 mm
O	Crawler Base	1,205 mm	1,205 mm
P	Crawler Overall Length	1,570 mm	1,570 mm
Q	Crawler Overall Width - Crawler Retracted	980 mm	980 mm
Q'	Crawler Overall Width - Crawler Extended	1,300 mm	1,300 mm
R	Crawler Shoe Width	230 mm	230 mm



PROUDLY DISTRIBUTED BY



MATERIAL HANDLING

1800 425 438

toyotatakeuchi.com.au

© 2020 Takeuchi MFG. Co., Ltd. All Rights Reserved. In accordance with our established policy of continued improvement, specifications and features are subject to change without notice. Pictures may show options other than standard equipment.

FORM: TB217R Compact Excavator Spec Sheet - Jan. 2020